

# Kidde ECS Fire Suppression System Marine Series Component Description



Effective: June 2014

K-90-9140M

## Nitrogen Pressure Operated Siren

### FEATURES

- **Pressure Operated Mechanical Siren for Use with Nitrogen Actuation Arrangements**
- **Audible Pre-Discharge/Discharge Alarm Where Electrical Power is not Available/Permitted**
- **Can be Driven by 108 cu. in., 1040 cu. in. and 2300 cu. in. Nitrogen Cylinders**
- **One to Twenty Sirens per Circuit; Multiple Circuits Can be Installed**
- **Robust Perforated Hood Protects Against Damage**
- **Integral Filter ordering information**
- **RoHS Compliant**

### DESCRIPTION

The Kidde ECS System Nitrogen Pressure Operated Siren is designed for use with the 108 cu. in. pilot cylinder (P/N 877940), the 1040 cu. in. pilot cylinder (P/N 90-101040-000) and the 2300 cu. in. Siren Driver Cylinder (P/N 90-102300-100). Pressure Operated Sirens are used where mechanical-pneumatic predischarge or discharge alarms are required (typically where electrical sirens are not permitted).

The siren consists of a cast bronze body and a brass rotor mounted on a stainless steel shaft and sealed ball race. A red painted steel hood protects the unit. A filter is positioned in the inlet stub on the body immediately before the flow-controlling nozzle.

### OPERATION

The unit is operated when high-pressure nitrogen is fed to the unit from a driver cylinder. Driver cylinder operation is typically achieved by a slave actuation from the system pilot cylinder. The flow of nitrogen through the unit causes the rotor to spin, thereby generating a continuous high-pitched tone. When driving pressure is depleted, the rotor will run down and the unit will be silent.

### INSTALLATION



**WARNING**

The Nitrogen Operated Siren must only be used in a nitrogen actuation circuit with Kidde Fire Systems components, and within the Listed limitations. The use of alternative media and/or equipment could result in insufficient siren volume or duration.

Sirens must be securely mounted to a flat surface using both mounting holes in the unit body. Avoid placing a siren where the unit would be significantly obstructed by objects or structures within the risk. Position sirens to provide even sound distribution throughout the hazard area.

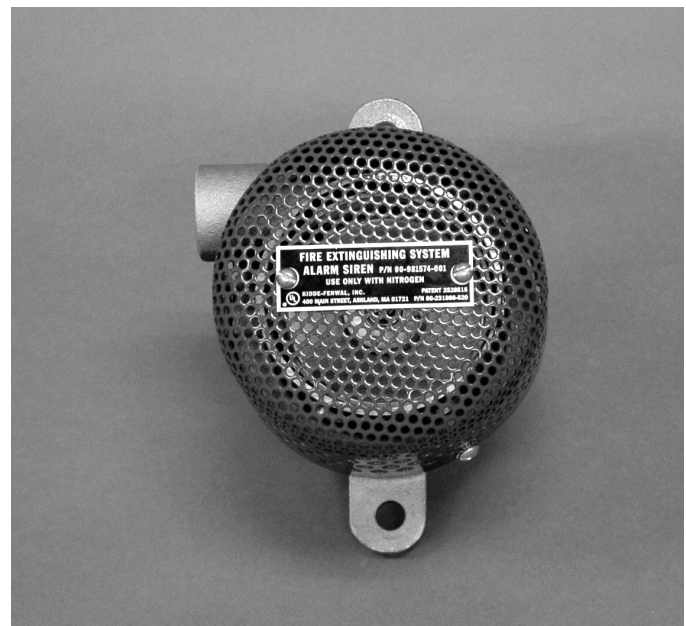

**WARNING**

Sirens are designed to generate in excess of 90 dB at a distance of 10 ft. (3.28 m). Sound levels at close proximity can potentially damage hearing. Wear hearing protection when working on system and position sirens to avoid unnecessary proximity to personnel.

Where possible, install a dirt trap at each siren connection. See the Marine ECS Design, Installation, Operation and Maintenance Manual (P/N 06-236225-001) for typical installation detail.

Table 1 lists the number of sirens that can be driven for each size of pilot or siren driver cylinder, as well as pipe/tubing limitations.

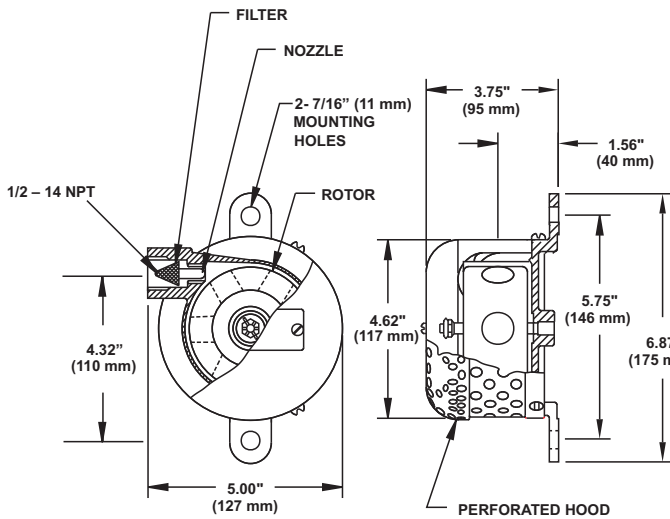

Figure 1. Nitrogen Pressure Operated Siren

## SPECIFICATIONS

**Operating Temperature Range:** 30°F to 130°F  
(0°C to 54°C)

**Nominal Flow Rate at 70° F (21°C):** 0.5 to 0.9lb./min  
(0.23 to 0.4kg/min)

**Minimum Full Duration  
Sound Output at 10 ft. (3.28 m):** 90dB

**Average Sound Output  
at 10 ft. (3.28 m):** 100dB+

**Mass:** 4 lb. (1.8 kg)

### Materials:

**Body-** Cast Bronze  
**Rotor-** Brass  
**Shaft/Bearing-** Stainless Steel  
**Nozzle/Filter-** Monel

## PERIODIC TESTING AND MAINTENANCE



**Before testing any components, ensure that the agent cylinder control heads are removed to prevent accidental system discharge.**

During annual (or more frequent) functional testing, the sirens should be inspected for damage or corrosion. Check for any blockages, and check that the rotor moves freely by either removing the protective hood or by applying pressure to the siren pipe network. Ensure that the connecting pipe work is undamaged and all joints/fittings are tight.

## ORDERING INFORMATION

Part Number	Description
90-981574-001	Nitrogen Pressure Operated Siren

Table 1: Nitrogen Pressure Operated Siren Data

Pilot Cylinder Size	Siren Part Number	Number of Sirens per Siren Driver	Maximum Length of 1/4" Sch. 80 Pipe	Maximum Length of 1/4" Sch. 40 Pipe	Maximum Length of 5/16" x 0.032" Wall Tubing
108 cu in	90-981574-001	1	90	90	90
1040 cu in	90-981574-001	4	500	500	500
2300 cu in	90-981574-001	10	500	500	500
2 x 2300 cu in	90-981574-001	20	500	500	500

FM-200 is a registered trademark of E.I. du Pont de Nemours and Company.  
 Kidde is a registered trademark of Kidde-Fenwal Inc. All other trademarks are the property of their respective owners.

This literature is provided for informational purposes only. Kidde-Fenwal, Inc. assumes no responsibility for the product's suitability for a particular application. The product must be properly applied to work correctly. If you need more information on this product, or if you have a particular problem or question, contact Kidde-Fenwal, Inc.

